

光电开关部分Photoelectric Switch

2.1光电开关型号及含义

Mode description of photoelectric switch

E3F - D S 30 C 4

(1) (2) (3) (4) (5) (6)

(1)外型序号 Outline & code:

E3F: 直径18圆柱、E3F3: 直径30圆柱、E3JK: 50*50*18

E3F: Diameter 18 column E3F3: Diameter 30 column E3JK: 50*50*18

E3JM: 25*65*75、E3S: 20*20*65、E3K80: 24*50*80 ...

(2)检出方式 Detection way:

D: 漫反射型Diffuse reflection type R: 反馈反射型 Feedback reflection type G: 槽型 Slot type

无表示: 对射型 No mark: Opposite type

(3)检出距离单位: Unit of detection distance

S: 厘米 Cm 无表示: 米 No mark: M

(4)检出距离具体数字; Detailed digit of detection distance

(5)输出形式: Type of output

N (C): NPN输出, 输出电流300mA

N (C): NPN output, output current 300mA

P: PNP输出, 输出电流300mA

P: PNP output, output current 300mA

Y:交流二线输制, 输出电流400mA

Y: AC twewire output system, output current 400mA

M: 交流或直流继电器输出,输出电流1A

M: AC or DC relay output, output current 1A

(6)输出状态: Output state

1 (4): 常开 2: 常闭 3: 常开+常闭

1 (4): NO 2: NC 3. NO+NC

● 2.2 光电开关的工作原理 Working principle of photoelectric switch

发射器对准目标不间断发射光束，接收器把接收到的光能量转换为电流传输给后面的检测线路，检测电路把该电流信号检出放大并输出。如图：

First, emitter aims at the object and emits the beams uninterruptedly, then, the receiver transfers the receiving optical energy to the current, and the current transmits to the back detection circuit, at last, the detected circuit detects and amplifies the current signal and outputs.

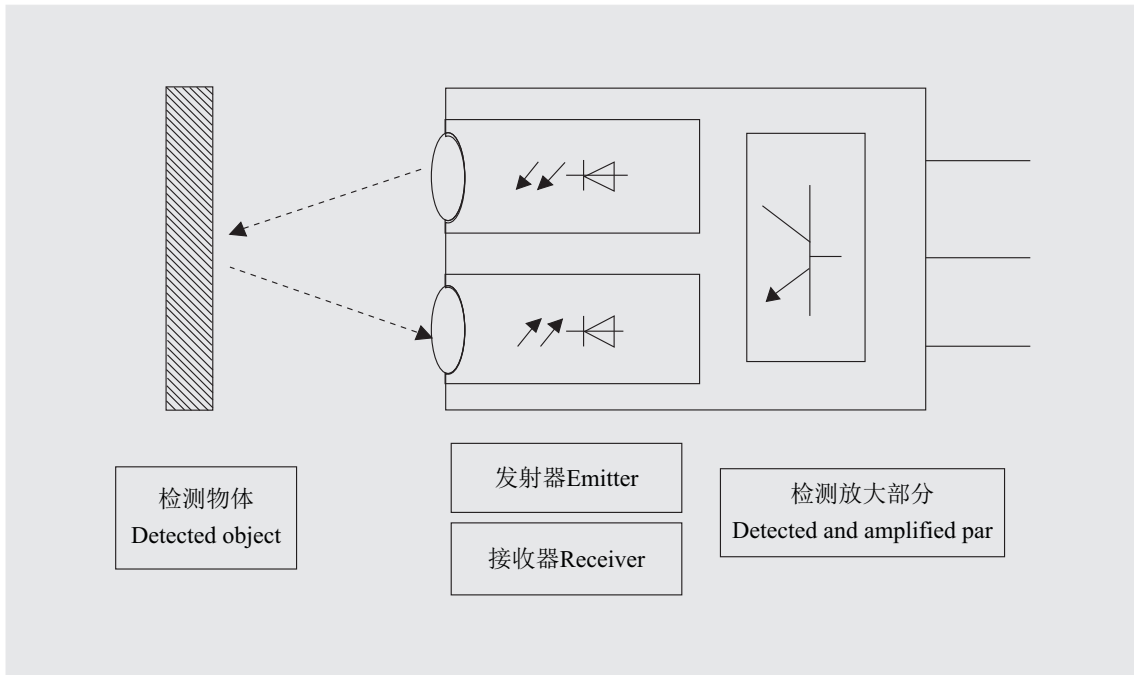

● 2.3 光电开关的技术用语 Technical terms of photoelectric switch

滞后距离（回差）：指测量板靠近光电开关产生的动作距离和复位距离之差；滞后距离用开关距离的百分比来表示。如图：

Lag distance (return difference): The difference between operation distance caused by when measurement plate approaches to photoelectric switch and resetting distance. It is represented by the percentage of switch distance, as shown in following figure.

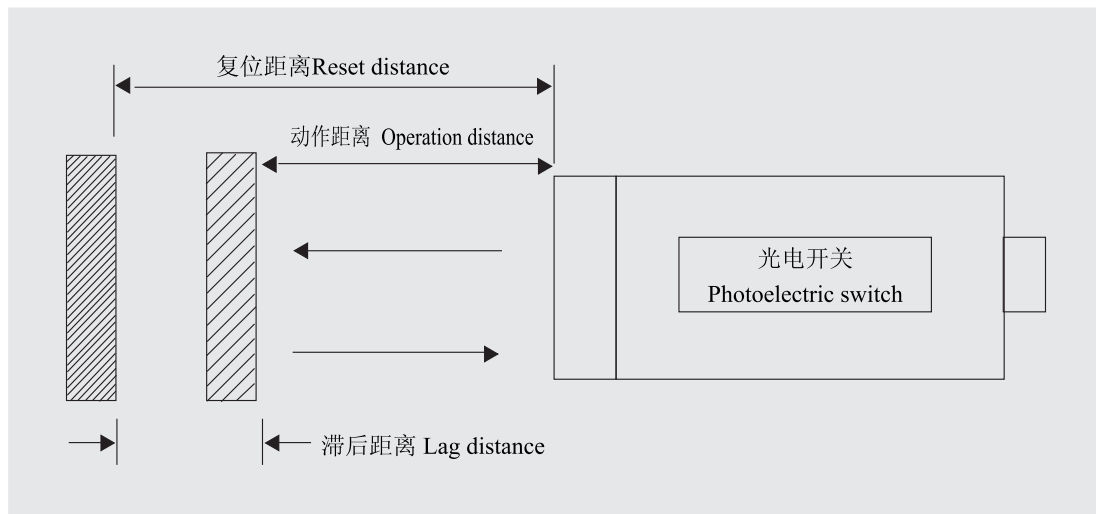

对射型 (透过型) : 对射型光电开关是将发光器与受光器置于相对的两个装置内, 光束也是在相对的两个装置之间, 穿达发光器与受光器之间的物体会阻断光束并启动受光器。

Opposite type: Opposite type photoelectric switch is designed into this structure that the light projector and light receiver are located in opposite two devices, the beam is placed between two devices, and the object goes through between the light projector and light receiver to block the beam and start the light receiver.

特点: 1、辨别不透明的物体; 2、有效距离大;
3、不易受干扰; 4、装置消费高;

Features: 1. Distinguish nontransparent object; 2. Large effective distance
3. Not interfered easily 4. High cost of device

如图: As shown in figure

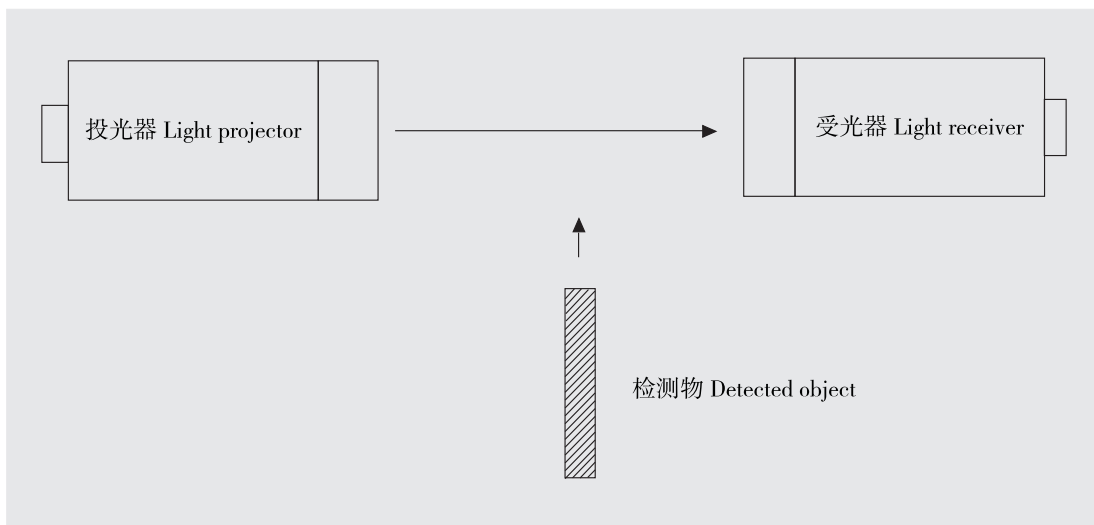

扩散反射型 (漫反射型) : 将投光器与受光器置于同一体内, 光电开关发射的光被检测物体反射回来受光器。

Diffuse reflection type: This type presents that the light projector and light receiver are located in the same body, the light of emitting from photoelectric switch is reflected by detected object to light receiver.

特点: 1、有效距离是由目标的反射能力决定的, 是由表面性质和颜色决定的。

Features: 1. Effective distance is determined by reflection capacity of object, surface property and color.

2、较小的装备开支, 可达到粗定位。

Low cost of device, rough location

3、对目标上的灰尘等引起的反射性变化敏感。

It is sensitive to the change of reflection resulted from the dust on the object.

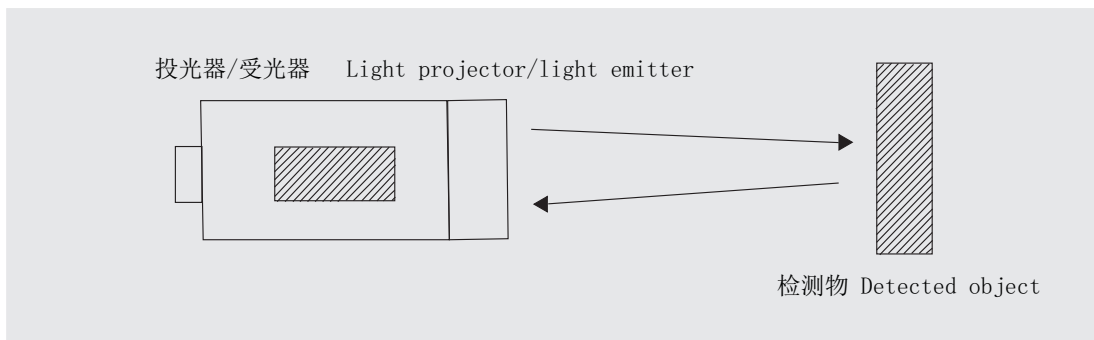

反馈反射型：（反光板型）：将投光器和受光器置于一体，不同于其他模式，它是采用反射板将光束反射到光电开关，光电开关与反射板之间的物体虽然也会反射光线，但其效率远低于反射板，因为切断反射光束。

Feedback reflection type: This type shows that the light projector and light receiver are set in the same device, different with other modes. It makes use of the illuminator to reflect the beam to the photoelectric switch, the object between the photoelectric switch and reflection plate can reflect the beams, but it also can cut off them, so the efficiency is far lower than the that of reflection plate,

- 特点：1、辨别不透明的物体；
 2、借助反射镜部位，形成高的有效距离；
 3、不易受干扰

- Features: 1. Distinguish the nontransparent object.
 2. Form high-efficiency distance resorting to the part of reflecting mirror.
 3. Not interfered easily

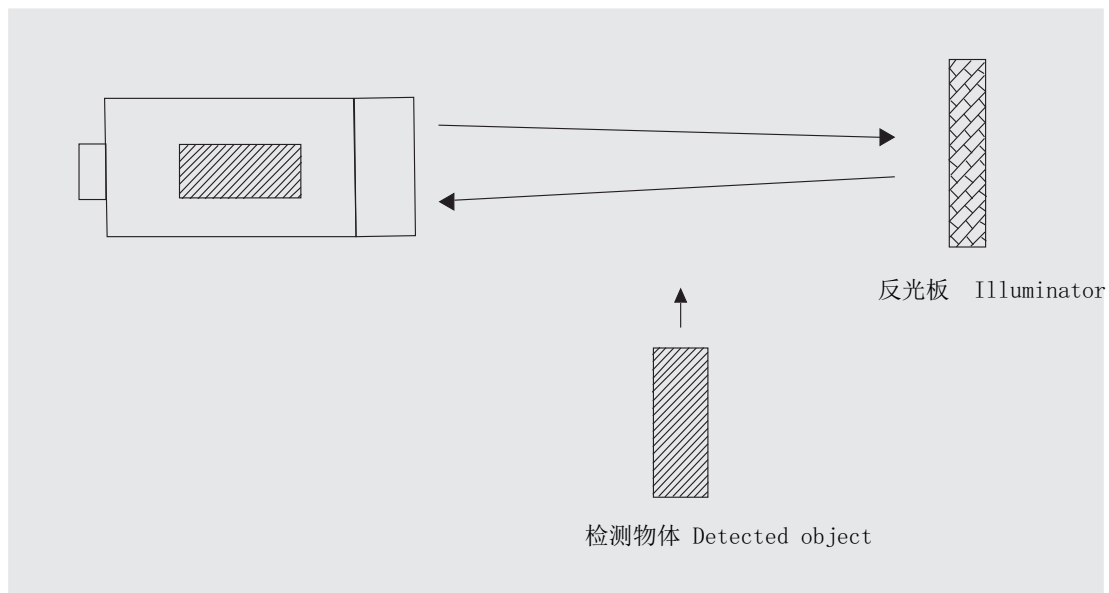

指向角：对射型、反射型能保证光电开关能稳定工作的角度范围。

Direction angle: This refers to the angle range that the opposite type and reflection type can guarantee the photoelectric switch works stably.

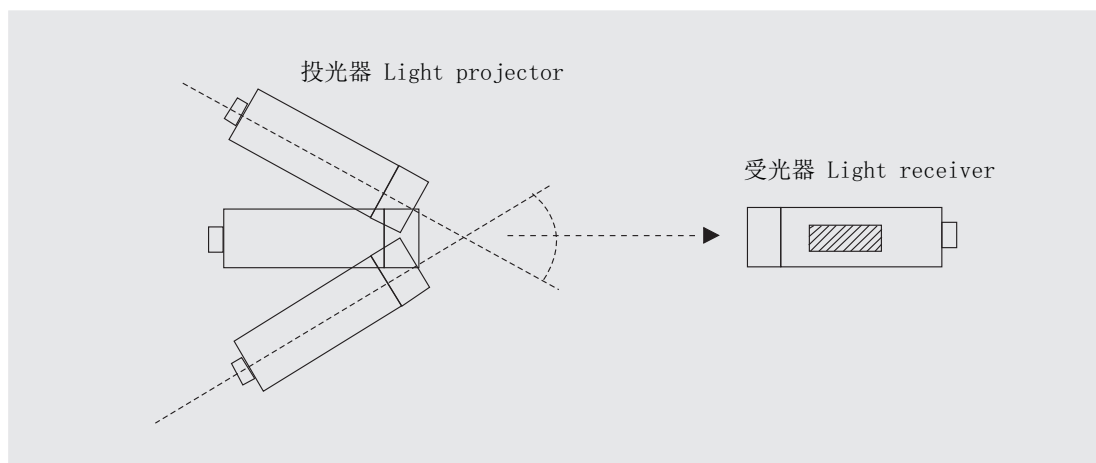













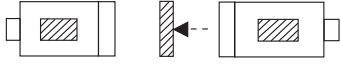

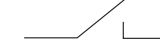
常开（常闭）：无检测物体时开关处于断开状态，有检测物体时开关处于闭合状态称为常开

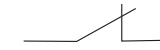
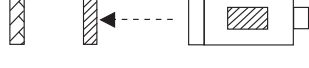
NO (NC): If without detected object, the switch is in breaking state; if detected object exists, the switch is in the closed state, named NO state.

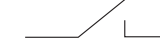
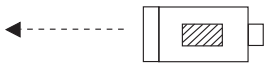
无检测物体时开关处于闭合状态，有检测物体时开关处于断开状态称为常闭。如图：

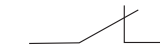
If without detected object, the switch is in closed state; if detected object exists, the switch is in the breaking state, named

NC state, as shown in following figure:

类型Type	图例Illustration	常开NO	常闭NC
对射型光电开关 Opposite type	 <p>无检测物体时 Without detected object</p>		
	 <p>有检测物体时 Detected object</p>		
反射板型光电开关 Feedback reflection type	 <p>无检测物体时 Without detected object</p>		
	 <p>有检测物体时 Detected object</p>		
漫反射型光电开关 Diffuse reflection type	 <p>无检测物体时 Without detected object</p>		
	 <p>有检测物体时 Detected object</p>		

● 2.4使用注意事项Application notice

1、安装时要防止相互干扰

1、Prevent interaction during installing

2、配线应单独配金属软管，请不要与电力线、动力线一起在同一金属软管内。

2、The installing wire should be in the metal hose separately, never put it with electric wire or power wire in the same metal hose.

3、请在额定电压范围内使用。

3、Use the switch within the range of rated voltage

4、下列安装场合使用时会造成误动作，请加以注意：

4、Please pay more attention to following locations that can result in misoperation.

(1)灰尘较多的场合。Place with many dusts.

(2)腐蚀性气体较多的场合。Place with many corrosive gas

(3)水、油、药剂等直接溅散的场合。Place with water, oil and medicament directly spraying

(4)太阳光等强光直接照射的场合。

Place with strong light like sunshine directly irradiating

(5)使用时的环境温度应在额定温度范围内。

Applicable environment temperature should be within the range of rated temperature.



● 2.5主要技术指标 Main technical indexes

回差 Returning difference	漫反射型Diffuse reflection type <15%
响应时间Response time	直流DC: <10mS 交流AC: <40mS 继电器Relay: <40mS
电源电压Supply voltage	直流DC10~30V 交流AC90~250V
开关容量Switch capacity	直流DC200mA 交流AC400mA
消耗电流Consumed current	直流3线 DC 3-wire; 13mA以下 13mA below
漏电流Leakage current	直流三线 DC 3-wire: 0.05mA以下 交流2线AC 2-wire: 1.7mA以下 1.7mA below
残余电压 Residual voltage	直流三线DC 3-wire: 2V以下 交流2线AC 2-wire: 6V以下 6V below
环境照度Environment illumination	白炽灯Incandescent lamp: 3000LX 太阳光Sunshine: 1000LX
环境温度Environment temperature	动作时Operation:-20~55OC 保存时 Preservation:-40~55OC (不结露、不结冰No dewfall or ice)
环境湿度Environment humidity	动作时、保存时Operation & preservation: 各35~95%RH 35~95%RH for each
绝缘阻抗 Insulation impedance	50MΩ以上 (充电部与外客间) 50MΩ above (between charging part and housing)
耐电压 Withstand voltage	AC1000V 50/60Hz 1min (充电部与外壳间) (between charging part and housing)

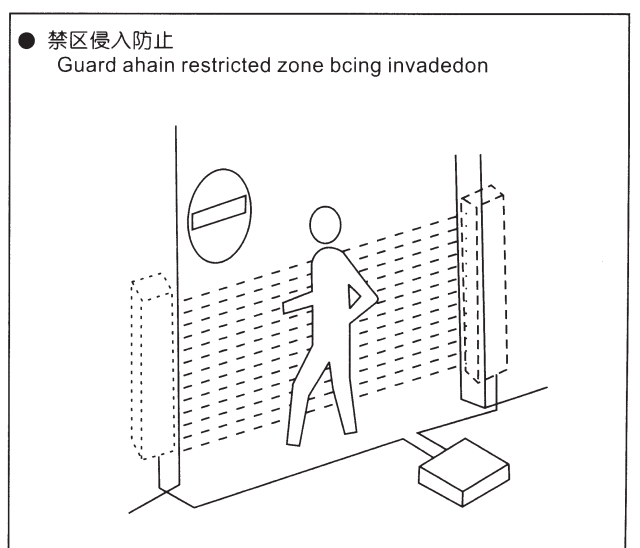
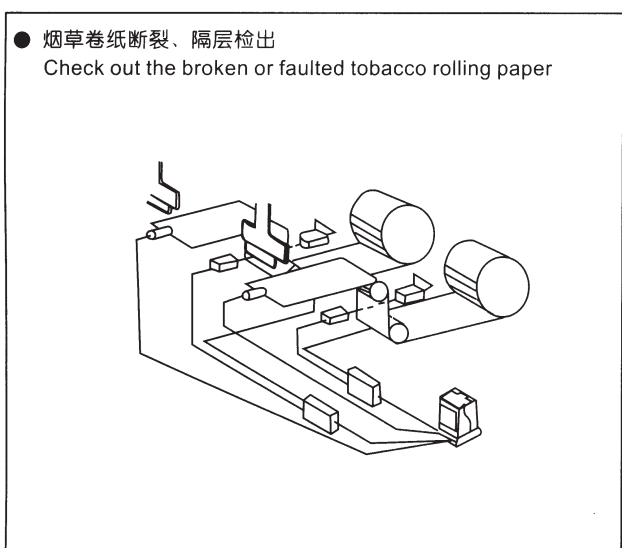
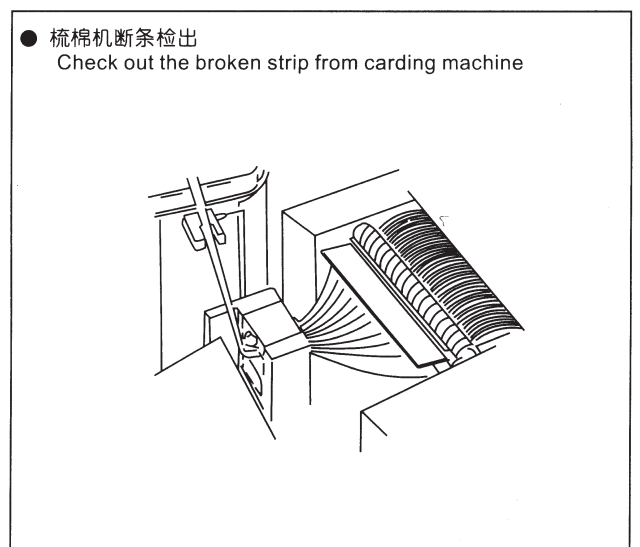
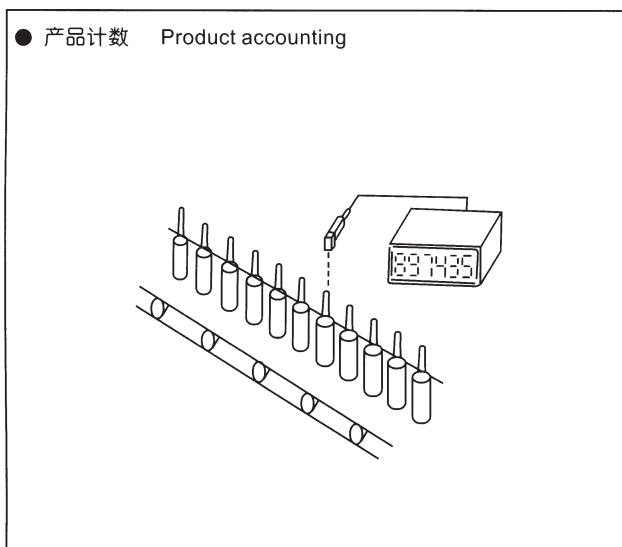
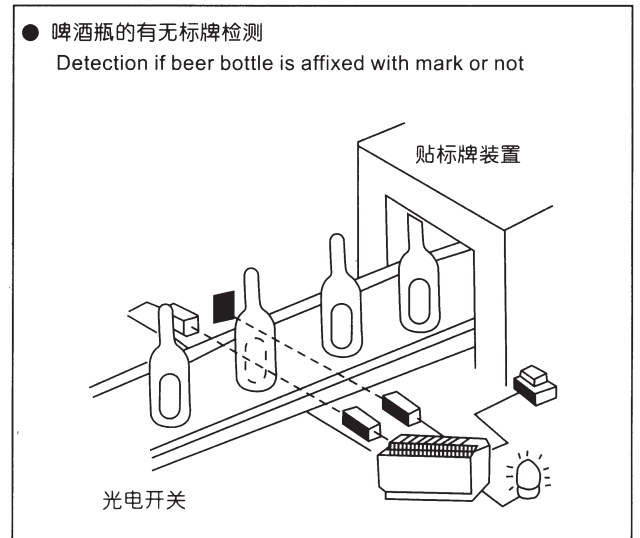
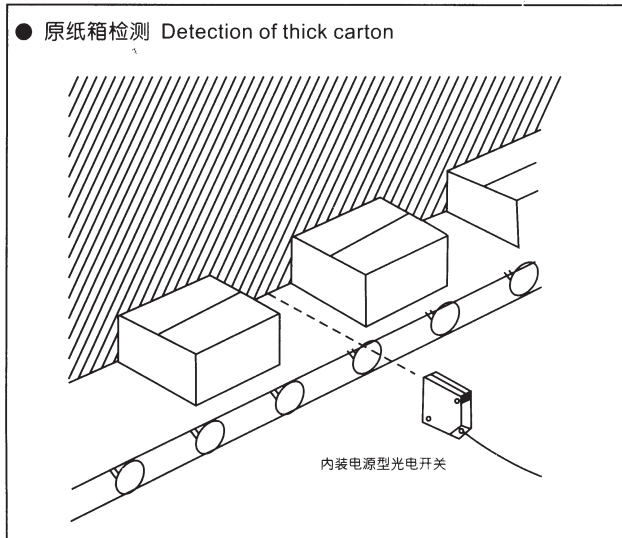
● 2.6 光电开关应用图例 Application illustration of photoelectric switch

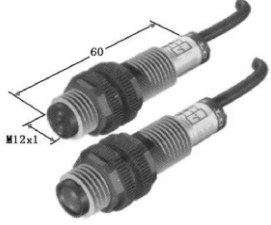

● 2.7光电开关型号介绍 Model description of photoelectric switch
 (可与欧姆龙直接替换) (Take the place of Ormon products directly)

外形及几何尺寸 Overall dimensions					
漫反射型 Diffuse reflection type	感应距离 Inductance distance		10cm	10cm(30cm)	
	直流 DC	NPN	常开NO	E3F1-DS10N1	E3F-DS10 (30) N1
			常闭NC	E3F1-DS10N2	E3F-DS10 (30) N2
		PNP	常开NO	E3F1-DS10P1	E3F-DS10 (30) P1
			常闭NC	E3F1-DS10P2	E3F-DS10 (30) P2
	交流 AC	二线制 Twire	常开NO	E3F1-DS10Y1	E3F-DS10 (30) Y1
常闭NC			E3F1-DS10Y2	E3F-DS10 (30) Y2	
五线继电器输出Five-wire relay output					
回归反射型 Retrereflection type	感应距离 Inductance distance		2m	2m	
	直流 DC	NPN	常开NO	E3F1-R2N1	E3F-R2N1
			常闭NC	E3F1-R2N2	E3F-R2N2
		PNP	常开NO	E3F1-R2P1	E3F-R2P1
			常闭NC	E3F1-R2P2	E3F-R2P2
	交流 AC	二线制 Twire	常开NO	E3F1-R2Y1	E3F-R2Y1
常闭NC			E3F1-R2Y2	E3F-R2Y2	
五线继电器输出Five-wire relay output					
对射型 Opposite type	感应距离 Inductance distance		3m	4m	
	直流 DC	NPN	常开NO	E3F1-3N1	E3F-4N1
			常闭NC	E3F1-3N2	E3F-4N2
		PNP	常开NO	E3F1-3P1	E3F-4P1
			常闭NC	E3F1-3P2	E3F-4P2
	交流 AC	二线制 Twire	常开NO		
常闭NC					
五线继电器输出Five-wire relay output					
外壳材料 Material of housing			塑料Plastic	塑料Plastic	
防护等级 Protection degree			IP67	IP67	
使用温度 Applicable temperature			-20℃~55℃	-20℃~55℃	

光电开关型号说明（可与欧姆龙直接替换）

Description for model of photoelectric switch (Take the place of Ormon products directly)

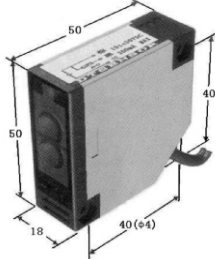
外形及几何尺寸 Overall dimensions					
漫反射型 Diffuse reflection type	感应距离 Inductance distance		70cm	30cm	
	直流 DC	NPN	常开NO	E3F3-DS70N1	
			常闭NC	E3F3-DS30N2	
		PNP	常开NO	E3F3-DS30P1	
			常闭NC	E3F3-DS30P2	
	交流 AC	二线制 Twire	常开NO	E3F3-DS30Y1	
			常闭NC	E3F3-DS30Y2	
五线继电器输出Five-wire relay output				E3JK-DS30M1	
回归反射型 Retroreflection type	感应距离 Inductance distance		4m	4m	
	直流 DC	NPN	常开NO	E3F3-R4N1	
			常闭NC	E3F3-R4N2	
		PNP	常开NO	E3F3-R4P1	
			常闭NC	E3F3-R4P2	
	交流 AC	二线制 Twire	常开NO	E3F3-R4Y1	
			常闭NC	E3F3-R4Y2	
五线继电器输出Five-wire relay output				E3JK-R4M1	
对射型 Opposite type	感应距离 Inductance distance		10m	5m	
	直流 DC	NPN	常开NO	E3F3-5N1	
			常闭NC	E3F3-5N2	
		PNP	常开NO	E3F3-5P1	
			常闭NC	E3F3-5P2	
	交流 AC	二线制 Twire	常开NO		
			常闭NC		
五线继电器输出Five-wire relay output				E3JK-5M1	
外壳材料 Material of housing			塑料Plastic	塑料Plastic	
防护等级 Protection degree			IP67	IP64	
使用温度 Applicable temperature			-20°C~55°C	-20°C~55°C	

光电开关型号说明（可与欧姆龙直接替换）

Description for model of photoelectric switch (Take the place of Ormon products directly)

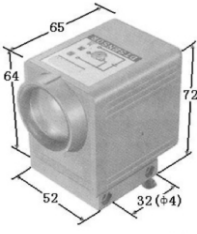
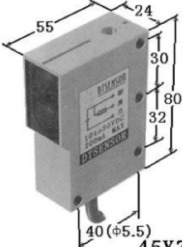
外形及几何尺寸 Overall dimensions				
漫反射型 Diffuse reflection type	感应距离 Inductance distance			80cm
	直流 DC	NPN	常开NO	E3K80-DS80N1
			常闭NC	E3K80-DS80N2
		PNP	常开NO	E3K80-DS80P1
			常闭NC	E3K80-DS80P2
	交流 AC	二线制 Twwire	常开NO	E3K80-DS80Y1
			常闭NC	E3K80-DS80Y2
五线继电器输出Five-wire relay output				
回归反射型 Retroreflection type	感应距离 Inductance distance			3m
	直流 DC	NPN	常开NO	E3K80-R3N1
			常闭NC	E3K80-R3N2
		PNP	常开NO	E3K80-R3P1
			常闭NC	E3K80-R3P2
	交流 AC	二线制 Twwire	常开NO	E3K80-R3Y1
			常闭NC	E3K80-R3Y2
五线继电器输出Five-wire relay output				
对射型 Opposite type	感应距离 Inductance distance		5m(10m)	8m
	直流 DC	NPN	常开NO	E3K80-8N1
			常闭NC	E3K80-8N2
		PNP	常开NO	E3K80-8P1
			常闭NC	E3K80-8P2
	交流 AC	二线制 Twwire	常开NO	
			常闭NC	
五线继电器输出Five-wire relay output		GDK5(10)		
外壳材料 Material of housing		塑料Plastic	塑料Plastic	
防护等级 Protection degree		IP64	IP64	
使用温度 Applicable temperature		-20℃~55℃	-20℃~55℃	

光电开关型号说明（可与欧姆龙直接替换）

Description for model of photoelectric switch (Take the place of Ormon products directly)

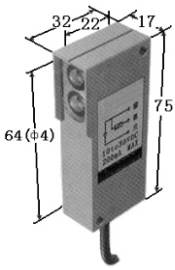
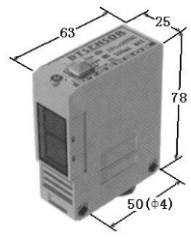
外形及几何尺寸 Overall dimensions					
漫反射型 Diffuse reflection type	感应距离 Inductance distance		20cm	80cm	
	直流 DC	NPN	常开NO	O-E3K75-DS20N1	O-E3K78-DS80N1
			常闭NC	O-E3K75-DS20N2	O-E3K78-DS80N2
		PNP	常开NO	O-E3K75-DS20P1	O-E3K78-DS80P1
			常闭NC	O-E3K75-DS20P2	O-E3K78-DS80P2
	交流 AC	二线制 Twire	常开NO		O-E3K78-DS80Y1
			常闭NC		O-E3K78-DS80Y2
五线继电器输出Five-wire relay output					
回归反射型 Retroreflection type	感应距离 Inductance distance		1.5m	3m	
	直流 DC	NPN	常开NO	O-E3K75-R2N1	O-E3K78-R3N1
			常闭NC	O-E3K75-R2N2	O-E3K78-R3N2
		PNP	常开NO	O-E3K75-R2P1	O-E3K78-R3P1
			常闭NC	O-E3K75-R2P2	O-E3K78-R3P2
	交流 AC	二线制 Twire	常开NO		
			常闭NC		
五线继电器输出Five-wire relay output					
对射型 Opposite type	感应距离 Inductance distance		4m	8m	
	直流 DC	NPN	常开NO	O-E3K75-4N1	O-E3K78-8N1
			常闭NC	O-E3K75-4N2	O-E3K78-8N2
		PNP	常开NO	O-E3K75-4P1	O-E3K78-8P1
			常闭NC	O-E3K75-4P2	O-E3K78-8P2
	交流 AC	二线制 Twire	常开NO		
			常闭NC		
五线继电器输出Five-wire relay output					
外壳材料 Material of housing			塑料Plastic	塑料Plastic	
防护等级 Protection degree			IP64	IP64	
使用温度 Applicable temperature			-20℃~55℃	-20℃~55℃	

光电开关型号说明（可与欧姆龙直接替换）

Description for model of photoelectric switch (Take the place of Ormon products directly)

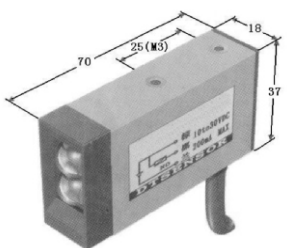
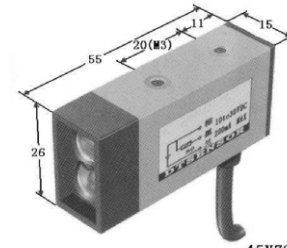
外形及几何尺寸 Overall dimensions					
漫反射型 Diffuse reflection type	感应距离 Inductance distance		50cm	50cm	
	直流 DC	NPN	常开NO	E3K55-DS50N1	E3K70-DS50N1
			常闭NC	E3K55-DS50N2	E3K70-DS50N2
		PNP	常开NO	E3K55-DS50P1	E3K70-DS50P1
			常闭NC	E3K55-DS50P2	E3K70-DS50P2
	交流 AC	二线制 Twwire	常开NO	E3K55-DS50Y1	E3K70-DS50Y1
			常闭NC	E3K55-DS50Y2	E3K70-DS50Y2
	五线继电器输出Five-wire relay output				
	回归反射型 Retroreflection type	感应距离 Inductance distance		2m	2m
		直流 DC	NPN	常开NO	E3K55-R2N1
常闭NC				E3K55-R2N2	E3K70-R2N2
PNP			常开NO	E3K55-R2P1	E3K70-R2P1
			常闭NC	E3K55-R2P2	E3K70-R2P2
交流 AC		二线制 Twwire	常开NO	E3K55-R2Y1	E3K70-R2Y1
			常闭NC	E3K55-R2Y2	E3K70-R2Y2
五线继电器输出Five-wire relay output					
对射型 Opposite type		感应距离 Inductance distance		5m	5m
		直流 DC	NPN	常开NO	E3K55-5N1
	常闭NC			E3K55-5N2	E3K70-5N2
	PNP		常开NO	E3K55-5P1	E3K70-5P1
			常闭NC	E3K55-5P2	E3K70-5P2
	交流 AC	二线制 Twwire	常开NO		
			常闭NC		
	五线继电器输出Five-wire relay output				
	外壳材料 Material of housing		塑料Plastic	塑料Plastic	
	防护等级 Protection degree		IP64	IP64	
使用温度 Applicable temperature		-20℃~55℃	-20℃~55℃		

光电开关型号说明（可与欧姆龙直接替换）

Description for model of photoelectric switch (Take the place of Ormon products directly)

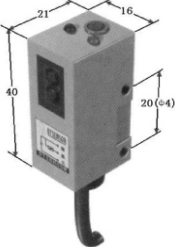
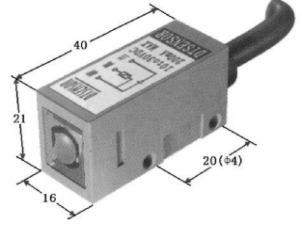
外形及几何尺寸 Overall dimensions					
漫反射型 Diffuse reflection type	感应距离 Inductance distance		30cm		
	直流 DC	NPN	常开NO	E3S-DS30N1	
			常闭NC	E3S-DS30N2	
		PNP	常开NO	E3S-DS30P1	
			常闭NC	E3S-DS30P2	
	交流 AC	二线制 Twire	常开NO	E3S-DS30Y1	
			常闭NC	E3S-DS30Y2	
五线继电器输出Five-wire relay output					
回归反射型 Retroreflection type	感应距离 Inductance distance		1m		
	直流 DC	NPN	常开NO	E3S-R1N1	
			常闭NC	E3S-R1N2	
		PNP	常开NO	E3S-R1P1	
			常闭NC	E3S-R1P2	
	交流 AC	二线制 Twire	常开NO	E3S-R1Y1	
			常闭NC	E3S-R1Y2	
五线继电器输出Five-wire relay output					
对射型 Opposite type	感应距离 Inductance distance		5m	5m	
	直流 DC	NPN	常开NO	E3S-5N1	E3S2-5N1
			常闭NC	E3S-5N2	E3S2-5N2
		PNP	常开NO	E3S-5P1	E3S2-5P1
			常闭NC	E3S-5P2	E3S2-5P2
	交流 AC	二线制 Twire	常开NO		
			常闭NC		
五线继电器输出Five-wire relay output					
外壳材料 Material of housing		塑料Plastic		塑料Plastic	
防护等级 Protection degree		IP64		IP64	
使用温度 Applicable temperature		-20℃~55℃		-20℃~55℃	

光电开关型号说明（可与欧姆龙直接替换）

Description for model of photoelectric switch (Take the place of Ormon products directly)

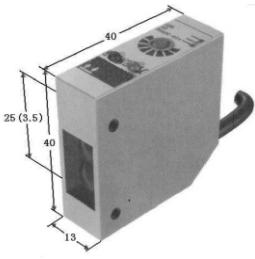
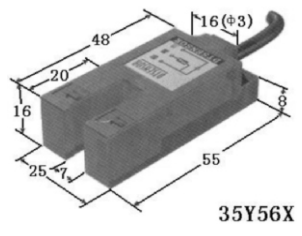
外形及几何尺寸 Overall dimensions					
漫反射型 Diffuse reflection type	感应距离 Inductance distance		50cm		
	直流 DC	NPN	常开NO	E3K40-DS50N1	
			常闭NC	E3K40-DS50N2	
		PNP	常开NO	E3K40-DS50P1	
			常闭NC	E3K40-DS50P2	
	交流 AC	二线制 Twire	常开NO		
			常闭NC		
五线继电器输出Five-wire relay output					
回归反射型 Retroreflection type	感应距离 Inductance distance		2m		
	直流 DC	NPN	常开NO	E3K40-R2N1	
			常闭NC	E3K40-R2N2	
		PNP	常开NO	E3K40-R2P1	
			常闭NC	E3K40-R2P2	
	交流 AC	二线制 Twire	常开NO		
			常闭NC		
五线继电器输出Five-wire relay output					
对射型 Opposite type	感应距离 Inductance distance		5m	7mm	
	直流 DC	NPN	常开NO	E3K40-5N1	E3S-GS7N1
			常闭NC	E3K40-5N2	E3S-GS7N2
		PNP	常开NO	E3K40-5P1	E3S-GS7P1
			常闭NC	E3K40-5P2	E3S-GS7P2
	交流 AC	二线制 Twire	常开NO		
			常闭NC		
五线继电器输出Five-wire relay output					
外壳材料 Material of housing		塑料Plastic		塑料Plastic	
防护等级 Protection degree		IP64		IP64	
使用温度 Applicable temperature		-20℃~55℃		-20℃~55℃	

外形及几何尺寸 Overall dimensions					
漫反射型 Diffuse reflection type	感应距离 Inductance distance		30cm		
	直流 DC	NPN	常开NO	E3JM-DS30N1	
			常闭NC	E3JM-DS30N2	
		PNP	常开NO	E3JM-DS30P1	
			常闭NC	E3JM-DS30P2	
	交流 AC	二线制 Twire	常开NO	E3JM-DS30Y1	
			常闭NC	E3JM-DS30Y2	
五线继电器输出Five-wire relay output					
回归反射型 Retroreflection type	感应距离 Inductance distance		1m		
	直流 DC	NPN	常开NO	E3JM-R1N1	
			常闭NC	E3JM-R1N2	
		PNP	常开NO	E3JM-R1P1	
			常闭NC	E3JM-R1P2	
	交流 AC	二线制 Twire	常开NO	E3JM-R1Y1	
			常闭NC	E3JM-R1Y2	
五线继电器输出Five-wire relay output					
对射型 Opposite type	感应距离 Inductance distance		5m		
	直流 DC	NPN	常开NO	E3JM-5N1	E3S-GS30N1
			常闭NC	E3JM-5N2	E3S-GS30N2
		PNP	常开NO	E3JM-5P1	E3S-GS30P1
			常闭NC	E3JM-5P2	E3S-GS30P2
	交流 AC	二线制 Twire	常开NO		
			常闭NC		
五线继电器输出Five-wire relay output					
外壳材料 Material of housing			塑料Plastic	塑料Plastic	
防护等级 Protection degree			IP64	IP64	
使用温度 Applicable temperature			-20℃~55℃	-20℃~55℃	

所列型号不全，具体可来电咨询
Please contact us for the models not covered in the above table.